

# GN 513 | Steel Spring Loaded Positioning Elements

Metric Size

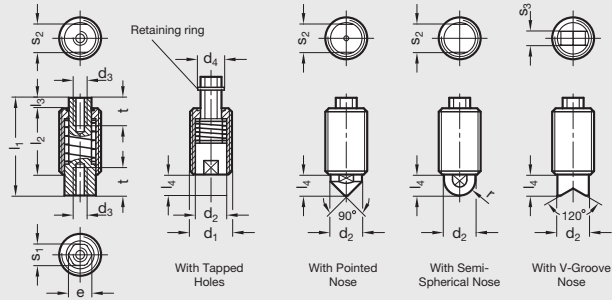

ISO 9001 Supplier

RoHS Compliant

### Threaded body

Steel, zinc-plated, blue passivated finish

### Standard spring load type

Black phosphate finish

### Heavy spring load type

Zinc-plated, blue passivated finish

### Plunger pin and pin casing

Steel, hardened, black oxide finish

Spring elements GN 513 are universal pressure elements used as detents, positioners or for clamping with spring pressure.

The spring loaded nose can be used for a push-on or push-off operation. In addition the spring loaded nose cannot rotate.

At the pulling end the female thread can accept a threaded rod, an operating knob, or any other mating threaded element.

Female thread type can also accept a special type or special length of plunger nose.

The spring loaded element can be screwed into a thread at the hexagon on the pulling end or the wrench flats at the pushing end of the plunger.

10

## With Tapped Holes

Dimensions in: millimeters (inches)

Part Number		d <sub>1</sub> Thread	d <sub>2</sub>	d <sub>3</sub> Tapped	d <sub>4</sub>	e	l <sub>1</sub>	l <sub>2</sub>	l <sub>3</sub>	l <sub>4</sub>	r	s <sub>1</sub>	s <sub>2</sub>	t min.	Spring Load N <sup>+</sup> Normal		Spring Load N <sup>+</sup> Higher	
Standard Spring Load	Heavy Spring Load														Initial	End	Initial	End
120FSG5/K	120FSG5/KS	M12 x 1.5	9 (.35)	M4 x .7	7.6 (.30)	6.5 (.26)	28 (1.10)	19 (.75)	3 (.12)	6 (.24)	4.5 (.18)	6 (.24)	8 (.31)	8 (.31)	16	35	18	56
160FSG5/K	160FSG5/KS	M16 x 1.5	12 (.47)	M5 x .8	8.8 (.35)	7.8 (.31)	38 (1.50)	27 (1.06)	3 (.12)	8 (.31)	6 (.24)	7 (.28)	10 (.39)	10 (.39)	25	71	45	125
200XSG5/K	200XSG5/KS	M20 x 1.5	14.5 (.57)	M6 x 1.0	11.4 (.45)	10 (.39)	47 (1.85)	33 (1.30)	4 (.16)	10 (.39)	7.2 (.28)	9 (.35)	12 (.47)	12 (.47)	40	130	65	200

## With Pointed Nose (90°)

Dimensions in: millimeters (inches)

Part Number		d <sub>1</sub> Thread	d <sub>2</sub>	d <sub>3</sub> Tapped	d <sub>4</sub>	l <sub>1</sub>	l <sub>2</sub>	l <sub>3</sub>	l <sub>4</sub>	s <sub>2</sub>	t min.	Spring Load N <sup>+</sup> Normal		Spring Load N <sup>+</sup> Higher	
Standard Spring Load	Heavy Spring Load											Initial	End	Initial	End
120FSG6/K	120FSG6/KS	M12 x 1.5	9 (.35)	M4 x .7	7.6 (.30)	28 (1.10)	19 (.75)	3 (.12)	6 (.24)	8 (.31)	8 (.31)	16	35	18	56
160FSG6/K	160FSG6/KS	M16 x 1.5	12 (.47)	M5 x .8	8.8 (.35)	38 (1.50)	27 (1.06)	3 (.12)	8 (.31)	10 (.39)	10 (.39)	25	71	45	125
200XSG6/K	200XSG6/KS	M20 x 1.5	14.5 (.57)	M6 x 1.0	11.4 (.45)	47 (1.85)	33 (1.30)	4 (.16)	10 (.39)	12 (.47)	12 (.47)	40	130	65	200

Indexing, Spring and Ball Plungers

### With Semi-Spherical Nose

Dimensions in: millimeters (*inches*)

Part Number		d <sub>1</sub> Thread	d <sub>2</sub>	d <sub>3</sub> Tapped	d <sub>4</sub>	l <sub>1</sub>	l <sub>2</sub>	l <sub>3</sub>	l <sub>4</sub>	r	s <sub>2</sub>	t min.	Spring Load N <sup>-</sup> Normal		Spring Load N <sup>-</sup> Higher	
Standard Spring Load	Heavy Spring Load												Initial	End	Initial	End
120FSG7/K	120FSG7/KS	M12 x 1.5	9 (.35)	M4 x .7	7.6 (.30)	28 (1.10)	19 (.75)	3 (.12)	6 (.24)	4.5 (.18)	8 (.31)	8 (.31)	16	35	18	56
160FSG7/K	160FSG7/KS	M16 x 1.5	12 (.47)	M5 x .8	8.8 (.35)	38 (1.50)	27 (1.06)	3 (.12)	8 (.31)	6 (.24)	10 (.39)	10 (.39)	25	71	45	125
200XSG7/K	200XSG7/KS	M20 x 1.5	14.5 (.57)	M6 x 1.0	11.4 (.45)	47 (1.85)	33 (1.30)	4 (.16)	10 (.39)	7.2 (.28)	12 (.47)	12 (.47)	40	130	65	200

### With V-Groove Nose (120°)

Dimensions in: millimeters (*inches*)

Part Number		d <sub>1</sub> Thread	d <sub>2</sub>	d <sub>3</sub> Thread	d <sub>4</sub>	l <sub>1</sub>	l <sub>2</sub>	l <sub>3</sub>	l <sub>4</sub>	s <sub>3</sub>	t min.	Spring Load N <sup>-</sup> Normal		Spring Load N <sup>-</sup> Higher	
Standard Spring Load	Heavy Spring Load											Initial	End	Initial	End
120FSG8/K	120FSG8/KS	M12 x 1.5	9 (.35)	M4 x .7	7.6 (.30)	28 (1.10)	19 (.75)	3 (.12)	6 (.24)	4 (.16)	8 (.31)	16	35	18	56
160FSG8/K	160FSG8/KS	M16 x 1.5	12 (.47)	M5 x .8	8.8 (.35)	38 (1.50)	27 (1.06)	3 (.12)	8 (.31)	6 (.24)	10 (.39)	25	71	45	125
200XSG8/K	200XSG8/KS	M20 x 1.5	14.5 (.57)	M6 x 1.0	11.4 (.45)	47 (1.85)	33 (1.30)	4 (.16)	10 (.39)	8 (.31)	12 (.47)	40	130	65	200