

# GN 810-NI | Stainless Steel Vertical Acting Toggle Clamps

Metric Size • With Horizontal Mounting Base



Type E  
with clamping bolt retainer  
for welding



Type A  
with two stepped  
side washers

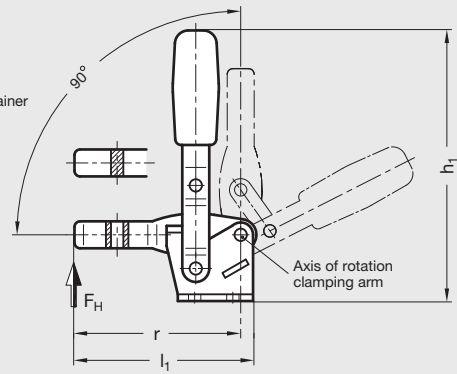

ISO 9001 Supplier

RoHS Compliant

## Toggle clamp

Stainless steel, European Standard No. 1.4301 (American Standard Series 304), bushings have bearing spots greased

## Hand Grip

High quality, oil resistant red plastic

## Type A

U-bar version with two flanged washers

## Type E

Solid bar version with clasp

Clamping screw assemblies not included, assemblies pages begin at page 833.

The hold-down bar and the handle move in the same direction. Clamps can be easily disassembled in order to adjust or reshape the parts according to usage requirements.

**GN 810-NI | Stainless Steel Vertical Acting Toggle Clamps | Metric Size • With Horizontal Mounting Base**

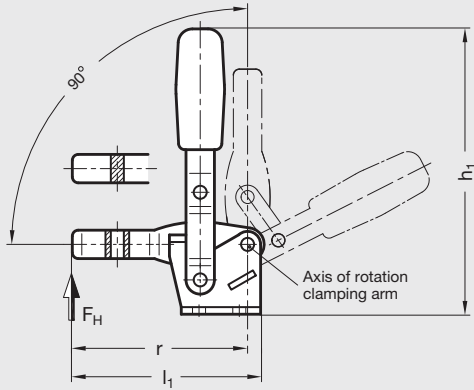

Type E  
with clamping bolt retainer  
for welding

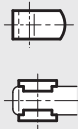

Type A  
with two stepped  
side washers

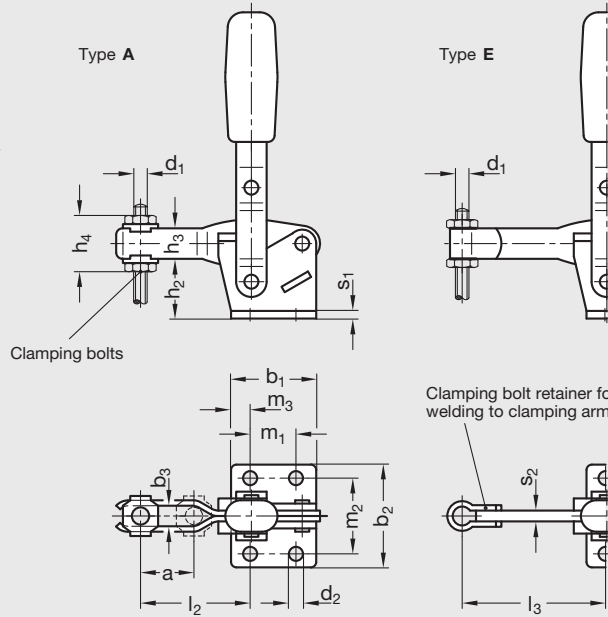

**Metric Table**

Dimensions in: millimeters (inches)

Part Number		Size Ref.	Holding Capacity FH[N]	a~	b <sub>1</sub>	b <sub>2</sub>	b <sub>3</sub>	d <sub>1</sub> Thread	d <sub>2</sub>	h <sub>1</sub>	h <sub>2</sub>
Type A U Bar	Type E Solid Bar										
70EVG8/A	70EVG8/E	70	900	20 (.79)	29 (1.14)	34 (1.34)	5.5 (.22)	M5 x .8	4.5 (.18)	98 (3.86)	19 (.75)
125EVG8/A	125EVG8/E	125	1600	28 (1.10)	35 (1.38)	42 (1.65)	6.5 (.26)	M6 x 1.0	5.5 (.22)	142 (5.59)	28 (1.10)
Size Ref.	h <sub>3</sub>	h <sub>4</sub> ~	l <sub>1</sub>	l <sub>2</sub>	l <sub>3</sub> max	m <sub>1</sub>	m <sub>2</sub>	m <sub>3</sub>	r	s <sub>1</sub>	s <sub>2</sub>
70	11 (.43)	22.5 (.89)	67 (2.64)	38 (1.50)	48 (1.89)	15 (.59)	24 (.94)	7 (.28)	62.5 (2.46)	2 (.08)	4 (.16)
125	14 (.55)	27 (1.06)	86 (3.39)	51 (2.01)	62 (2.44)	19 (.75)	29 (1.14)	8 (.31)	79 (3.11)	2.5 (.10)	5 (.20)