

GN 822 | Steel Mini Indexing Plungers

Metric Size • Non Lock-out Type

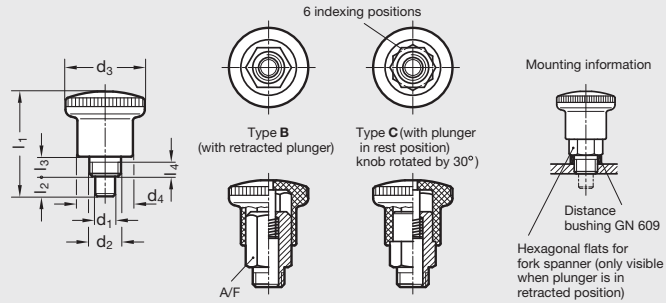

ISO 9001 Supplier

RoHS Compliant

Body

Steel, zinc-plated, blue passivated finish

Plunger

Stainless steel, European standard No. 1.4305 (American standard series 303)

Spring

Stainless steel, European standard No. 1.4305 (American standard series 303)

Knob

Matte black glass fiber reinforced nylon plastic, not removable

GN 822 indexing plungers feature small, compact dimensions. They are designed for installation in thin walled sheet metal applications.

Plungers are inserted into position by holding them by the knurled knob. The wrench flats on the lock nut are exposed when the pin is retracted, so that the plunger can be easily tightened by means of an open end wrench. GN 609 spacer bushings may be ordered separately upon request.

d1 pin tolerance = -.02 to .04 mm

d1 mating bore size tolerance = +.05 to .1 mm

Metric Table

Dimensions in: millimeters (inches)

Part Number	d ₁ Pin Dia.	d ₂ Thread	d ₃	d ₄	l ₁	l ₂ min.	l ₃	l ₄ min.	A/F (h ₁₁ tol.)	Spring Load N-	
										Start	End
8XRM0	4 (.16)	M8 x .75	21 (.83)	15 (.59)	26.5 (1.04)	5 (.20)	5 (.20)	3.5 (.14)	10 (.39)	4.5	12
8XRM1	5 (.20)	M8 x .75	21 (.83)	15 (.59)	26.5 (1.04)	5 (.20)	5 (.20)	3.5 (.14)	10 (.39)	4.5	12
100XRM2	6 (.24)	M10 x 1	25 (.98)	18 (.71)	34 (1.34)	7 (.28)	7 (.28)	4.5 (.18)	12 (.47)	5	18
100XRM3	7 (.28)	M10 x 1	25 (.98)	18 (.71)	34 (1.34)	7 (.28)	7 (.28)	4.5 (.18)	12 (.47)	5	18

10

Indexing, Spring and Ball Plungers