

GN 844 | Steel Heavy Duty Push-Pull Type Toggle Clamps

Metric Size

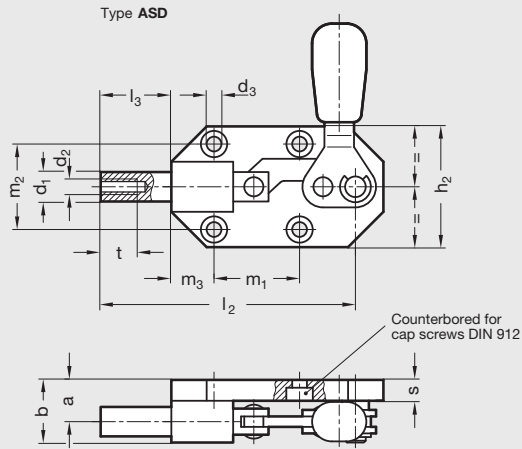

Type ASS is mirror image of type ASD

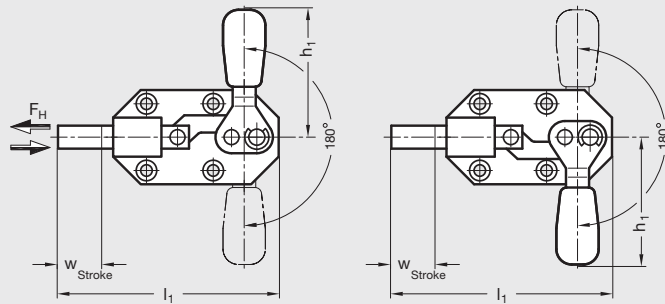

ISO 9001 Supplier

RoHS Compliant

Toggle clamp

Lever arm case-hardened sheet metal (steel C10), zinc plated, blue passivated
 Rod is St. 37 steel, zinc plated, blue passivated
 Base is brass, black lacquered finish
 All mobile sections lubricated with special grease

Hand Grip

High quality, oil resistant red plastic

Type ASD

Compression occurs with counter-clockwise turn

Type ASS

Compression occurs with clockwise turn

Clamping screw assemblies not included, assemblies pages begin at page 855.

In these devices the circular movement of the handle is transformed into a straight-line action of the clamp along its axis.

Metric Table

Dimensions in: millimeters (*inches*)

Part Number		Size Ref.	Holding Capacity FH[N]	a	b	d ₁	d ₂ Tapped	d ₃	h ₁ ~	h ₂
Type ASD Counter-clockwise Turn	Type ASS Clockwise Turn									
70EVU4/ASD	70EVU4/ASS	70	900	12 (.47)	19 (.75)	8.5 (.33)	M6 x 1.0	4.5 (.18)	49 (1.93)	36 (1.42)
160EVU4/ASD	160EVU4/ASS	160	1300	15.5 (.61)	25 (.98)	11 (.43)	M6 x 1.0	5.5 (.22)	86 (3.39)	46 (1.81)

Size Ref.	l ₁	l ₂ ~	l ₃	m ₁	m ₂	m ₃	s	t	w Hub
70	86 (3.39)	77 (3.03)	21.5 (.85)	26 (1.02)	26 (1.02)	13 (.51)	6 (.24)	12 (.47)	20 (.79)
160	117 (4.61)	107 (4.21)	32 (1.26)	36.5 (1.44)	33.5 (1.32)	11 (.43)	10 (.39)	12 (.47)	30 (1.18)