

# SHA/SHA-MEP | Plastic Solid Disk Handwheels

With or without Revolving Handle

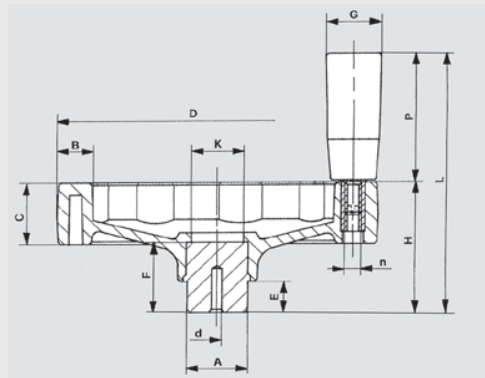

RoHS Compliant

5

Handwheels

## Handwheel body

Black, glass filled nylon plastic, matte finish

## Hub

Steel, zinc plated, molded-in

## Revolving handle

Black fiber reinforced nylon plastic hand piece with zinc plated steel threaded spindle

No mounting hole in handwheel rim for handwheel without handle

Handle shipped loose; mounting of handle is required

Both dimensions, inch and metric, are interchangeable

SHA glass filled nylon plastic handwheels with revolving handle are of modern design. They are an excellent choice for light to medium duty applications.

Maximum heat resistance of nylon plastic: 110°C (230°F).

Modifications such as inch and metric bores, keyways, set screw holes, etc. available upon request.

Countersunk washers for handwheel retention, see GN 184, page 661.

## Metric Table

Dimensions in: millimeters (inches)

Part Number		D	d Pilot Hole	H	L	C	B	A	E	F	K	G	P	n Thread
With Handle	Without Handle													
6380005	6379005	100 (3.94)	4 (.16)	46 (1.81)	96 (3.78)	20 (.79)	15 (.59)	24 (.94)	12 (.47)	24 (.94)	18 (.71)	21 (.83)	50 (1.97)	M6 x 1.0
6380010	6379010	125 (4.92)	6 (.24)	51 (2.01)	101 (3.98)	24 (.94)	17 (.67)	24 (.94)	12 (.47)	28 (1.10)	20 (.79)	21 (.83)	50 (1.97)	M6 x 1.0
6380015	6379015	160 (6.30)	6 (.24)	61 (2.40)	131 (5.16)	28 (1.10)	20 (.79)	32 (1.26)	15 (.59)	31 (1.22)	30 (1.18)	23 (.91)	70 (2.76)	M8 x 1.25
6380020	6379020	200 (7.87)	6 (.24)	74 (2.91)	164 (6.46)	32 (1.26)	24 (.94)	40 (1.57)	15 (.59)	40 (1.57)	35 (1.38)	26 (1.02)	90 (3.54)	M10 x 1.5