

EN 623 | Ergostyle® Plastic Control Levers

Technopolymer Plastic • With Through Bore • Metric Size

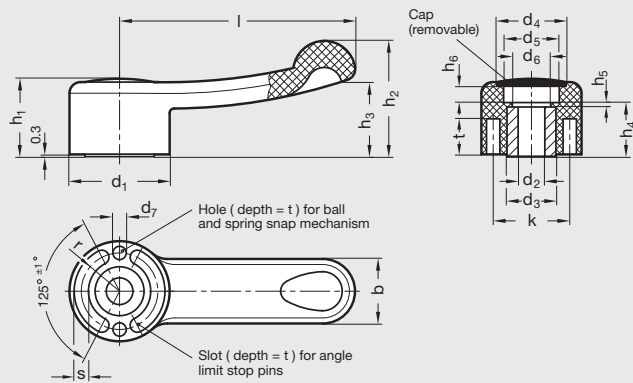

elesa®



2

Control Levers

ISO 9001 Supplier

RoHS Compliant

Body

Special glass-fiber reinforced technopolymer plastic, black matte finish

Hub

Steel, black oxide finish, molded in

Cover disk

Technopolymer plastic in one of the Ergostyle colors (black is standard), matte finish, supplied but not assembled, press-fit, removable with screwdriver

Optional colors

- C1** Black RAL 7021
- C2** Orange RAL 2004
- C3** Gray RAL 7035
- C4** Yellow RAL 1021
- C5** Light Blue RAL 5024
- C6** Red RAL 3000

Elesa® original design technopolymer plastic Ergostyle® control levers.

Operations are performed smoothly and powerfully thanks to the heavy-duty arm of the lever, while the enlarged and sunken semi-spherical end offers a comfortable support for the palm of the hand and an effective grip.

Resistant to solvents, oils, grease and other chemical agents.

Modifications such as metric and inch size bores, threads, keyways, etc. available upon request.

Elesa Model ELC

Metric Table

Dimensions in: millimeters (*inches*)

Part Number*	d ₁	Through Bore	d ₃	d ₄	d ₅	d ₆	d ₇	b	h ₁	h ₂	h ₃	h ₄	h ₅	h ₆	k	l	r	s	t
6MCA6/C1	32 (1.26)	6 (.236)	15 (.59)	22.5 (.89)	16 (.63)	10 (.39)	4 (.16)	20 (.79)	24 (.94)	35 (1.38)	24 (.94)	18 (.71)	2 (.08)	3 (.12)	24 (.94)	67 (2.64)	12 (.47)	4.3 (.17)	9 (.35)
8MCA7/C1	37 (1.46)	8 (.315)	18 (.71)	26 (1.02)	20 (.79)	13.5 (.53)	5 (.20)	23 (.91)	26.5 (1.04)	39.5 (1.56)	26 (1.02)	20 (.79)	2.5 (.10)	5 (.20)	26 (1.02)	85 (3.35)	13.8 (.54)	4.3 (.17)	12.5 (.49)
12MCA8/C1	46 (1.81)	12 (.472)	22 (.87)	31.5 (1.24)	25.5 (1.00)	17 (.67)	6 (.24)	29 (1.14)	35 (1.38)	54 (2.13)	36 (1.42)	24 (.94)	2 (.08)	8 (.31)	32 (1.26)	110 (4.33)	17.5 (.69)	6.5 (.26)	15.5 (.61)
14MCA9/C1	54 (2.13)	14 (.551)	26 (1.02)	36 (1.42)	31 (1.22)	21 (.83)	8 (.31)	34 (1.34)	38 (1.50)	60 (2.36)	38 (1.50)	29.5 (1.16)	2.5 (.10)	6 (.24)	39 (1.54)	140 (5.51)	20.2 (.80)	7.3 (.29)	16 (.63)

* For optional-standard colors replace the last digit with the desired suffix: **C1** (Black RAL 7021), **C2** (Orange RAL 2004), **C3** (Gray RAL 7035), **C4** (Yellow RAL 1021), **C5** (Light Blue RAL 5024), **C6** (Red RAL 3000). Example of part number for Orange RAL 2004 lever: .6MCA6/C2