

ALCK | Aluminum Control Knobs

Inch Size • With or without Fixed Handle

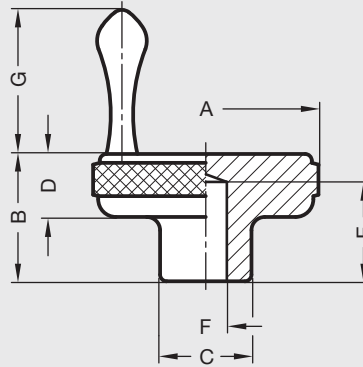

RoHS Compliant

Machined from aluminum bar stock
 Polished to a high luster
 Natural anodized finish
 Knurled outer rim
 Available with or without handle
 No mounting hole in knob without handle.

Used in applications that require more hand control such as gauging fixtures, precision instruments, printing equipment or where a high quality knob is necessary.
 Special bores, keyways, set screw holes and other handle types available upon request.

Blank Type

Dimensions in: inches (millimeters)

Part Number		A	F Bore	B	C	D	G
Without Handle	With Handle						
0BFK0	-	1.0 (25.4)	Blank	.81 (20.6)	.50 (12.7)	.38 (9.7)	-
0BFK1	0BFH0	2.0 (50.8)	Blank	1.13 (28.7)	.81 (20.6)	.56 (14.2)	1.28 (32.5)
0BFK2	0BFH1	3.0 (76.2)	Blank	1.25 (31.8)	1.25 (31.8)	.69 (17.5)	1.94 (49.3)

Blind Bore Type

Dimensions in: inches (millimeters)

Part Number		A	F Blind Bore	B	C	D	E	G
Without Handle	With Handle							
1BFK0	-	1.0 (25.4)	.250 (6.4)	.81 (20.6)	.50 (12.7)	.38 (9.7)	.63 (16.0)	-
3BFK1	3BFH0	2.0 (50.8)	.375 (9.5)	1.13 (28.7)	.81 (20.6)	.56 (14.2)	.88 (22.4)	1.28 (32.5)
5BFK2	5BFH1	3.0 (76.2)	.625 (15.9)	1.25 (31.8)	1.25 (31.8)	.69 (17.5)	.88 (22.4)	1.94 (49.3)