

# GN 612.1 | Steel Mounting Blocks

Metric Size • For Indexing Plungers

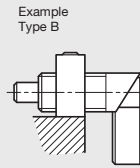
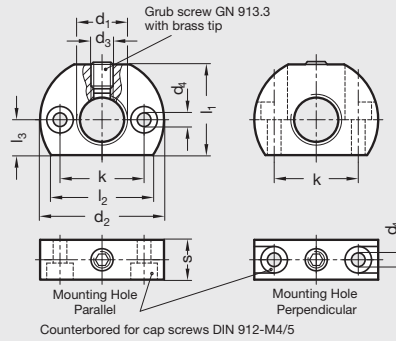

ISO 9001 Supplier

RoHS Compliant

## Block

Steel, black oxide finish

Steel set screw with brass tip, GN 913.3 series

Mounting options are available in either parallel or perpendicular to the indexing plunger.

GN 612.1 mounting blocks broaden the mounting possibilities and are an added feature for the GN 612 cam action indexing plunger. They can also be used with any of the M16 x 1.5 or M20 x 1.5 threaded body indexing plungers.

## Metric Table

Dimensions in: millimeters (*inches*)

Mounting Hole Parallel	Part Number		d <sub>1</sub> Thread	d <sub>2</sub>	k -0.1 mm	l <sub>1</sub>	l <sub>2</sub> ≈	l <sub>3</sub>	s
	Mounting Hole Perpendicular	Mounting Hole Perpendicular							
120FP74/A	120FP74/B	120FP74/B	M12 x 1.5	32 (1.26)	21 (.83)	22 (.87)	26.5 (1.04)	9 (.35)	12 (.47)
160FP20/A	160FP20/B	160FP20/B	M16 x 1.5	46 (1.81)	32 (1.26)	33 (1.30)	37 (1.46)	13 (.51)	15 (.59)
200XP20/A	200XP20/B	200XP20/B	M20 x 1.5						

10

Indexing, Spring and Ball Plungers