

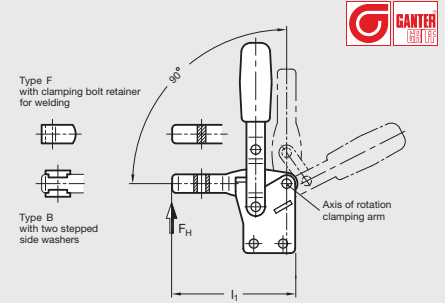

GN 810.1 | Vertical Acting Toggle Clamps

Metric Size • With Vertical Mounting Base

Toggle Clamp	Steel, zinc plated
Versions	U-bar with two flanged washers or solid bar with clasp
Holding	900 – 4600 N
Capacity	
Length l_1	2.64 – 8.86 inch (67 – 225 mm)



ISO 9001 Supplier

RoHS Compliant



NEW



GN 810.1-NI | Vertical Acting Toggle Clamps

Metric Size • With Vertical Mounting Base

SS

Toggle Clamp	Stainless steel
Versions	U-bar with two flanged washers or solid bar with clasp
Holding	900 – 1600 N
Capacity	
Length l_1	2.64 – 3.39 inch (67 – 86 mm)

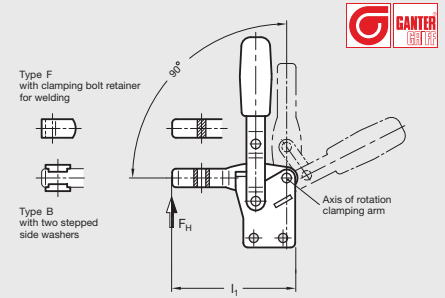

ISO 9001 Supplier

RoHS Compliant



GN 813 | Heavy Duty Vertical Acting Toggle Clamps

Metric Size • With Vertical Mounting Base

Toggle Clamp	Steel, zinc plated
Holding	10000 – 30000 N
Capacity	
Length l_1	7.48 – 9.84 inch (190 – 250 mm)

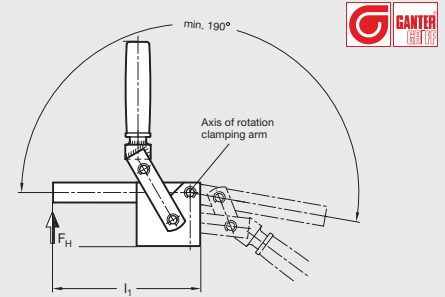

15

ISO 9001 Supplier

RoHS Compliant



NEW



GN 910.2 | Heavy Duty Knee Lever Modules

Metric Size • With Screw-on Mounting Base

Body	Steel, blackened finish
Mounting Hole	Vertical or parallel to axis of rotation
Holding	2200 – 4800 N
Capacity	
Length l_1	2.26 – 3.37 inch (57.5 – 85.5 mm)

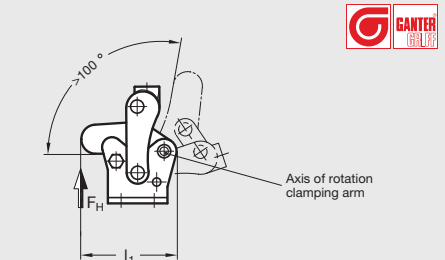

ISO 9001 Supplier

RoHS Compliant

Toggle Clamps