

MGR | Plastic Locking Retractable Handles

Inch and Metric Size • With Securing Pin

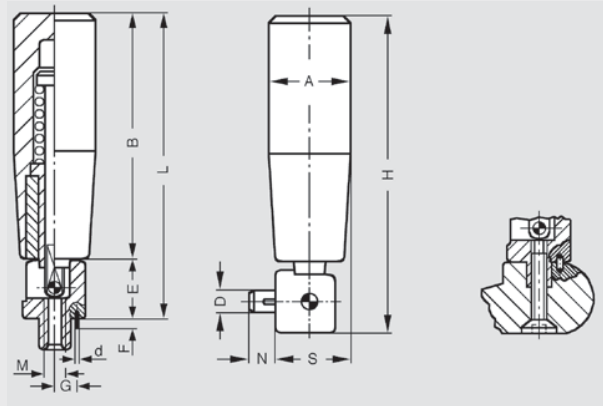

RoHS Compliant

4

Hand piece

Shiny black phenolic plastic, revolving

Spring loaded retractable mechanism

Chrome plated steel hub and zinc plated steel stem

Retractable handles are suitable when the handle must be withdrawn during automatic operation.

The handle is pulled out of its seating position and then tilted.

A compression spring locks the handle in both end positions.

A positive lock is achieved in the operating position by way of a tapered seating located in the hub of the mechanism.

When mounting the retracting mechanism to its mating surface, the securing pin gives the retractable handle more torque stability.

Maximum heat resistance of phenolic plastic: 150°C (300°F).

Inch Table

Dimensions in: inches (millimeters)

Part Number	A	M Tapped	D	N	d Pin Ø	F	G	E	L	H	B	S
8100228	1.10 (.28)	1/4-20	.31 (.8)	.39 (.10)	.10 (.25)	.16 (.4)	.30 (.75)	.79 (.20)	4.13 (105)	4.13 (105)	3.35 (.85)	.94 (.24)

Metric Table

Dimensions in: millimeters (inches)

Part Number	A	M Tapped	D	N	d Pin Ø	F	G	E	L	H	B	S
6151003	21 (.83)	M5 x .8	7 (.28)	8 (.31)	2.5 (.10)	4 (.16)	6.3 (.25)	16.5 (.65)	66.5 (.62)	69 (2.72)	50 (1.97)	19 (.75)
6151005	23 (.91)	M5 x .8	7 (.28)	8 (.31)	2.5 (.10)	4 (.16)	6.3 (.25)	16.5 (.65)	71.5 (.81)	74 (2.91)	55 (2.17)	20 (.79)
6151010	25 (.98)	M6 x 1.0	8 (.31)	8 (.31)	2.5 (.10)	4 (.16)	7.5 (.30)	16.5 (.65)	81.5 (3.21)	84 (3.31)	65 (2.56)	21 (.83)
6151015	28 (1.10)	M6 x 1.0	8 (.31)	10 (.39)	2.5 (.10)	4 (.16)	7.5 (.30)	20 (.79)	105 (4.13)	105 (4.13)	85 (3.35)	24 (.94)