

**Order No.: FLS15**

With serrated shoes - shown in wedge fully open position.



**Order No.: FLS15-ST**

With stepped shoes - shown in wedge closed position.



**Features & Benefits**

- 33,000 pound (15 metric ton) spreader features an incorporated wedge design that provides structural support to the shoes throughout the tool range to maximize tool longevity and performance.
- Jaws fully supported by wedge for excellent durability
- Ideal for flanges with narrow gaps - only 5 mm (.2 inches) required for entry
- Compact and lightweight design - only 287 mm (11.28 inches) long at a weight of 3.2 kg (7 pounds)
- Suitable for the offshore environment due to superior corrosion resistance
- Quick adjustments for various tasks due to interchangeable shoes (both stepped and serrated)
- Includes female half coupler - mates to standard 3/8" male half coupler (No. 9798).

**► FLS15 Serrated Shoe Spreader**

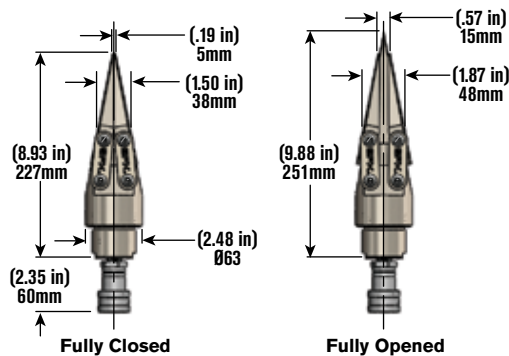

**► FLS15-ST Stepped Shoe Spreader**

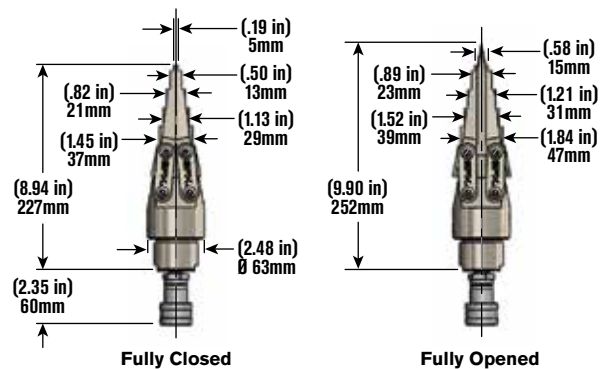

**► Ordering Information**

Order No.	Shoe Type	Maximum Spreading Force	Minimum Tip Clearance	Maximum Tip Spread	Spreader Type	Oil Capacity	Weight	Maximum Operating Pressure
		Metric Tons (lb)	mm (in)	mm (in)		cc (in <sup>3</sup> )	kg (lb)	bar (psi)
FLS15	Serrated	15 (33,000)	5 (0.19)	15 (.57)	Hydraulic	16 (1)	3.2 (7)	700 (10,000)
FLS15-ST	Stepped							

▶ **Topside Flange Spreader Kit**



**Features & Benefits**

- Standard duty blow molded case organizes and protects the complete spreading kit
- Extra storage space for additional step shoes and up to 3 step blocks
- CE kits designed for European market and have a “bar” gauge
- Non-CE kits are for American market and have a “psi” gauge

Order No.		Kit Contents							
		FLS15	FLS15-ST	SB15	P19L			2008410	2008650
		Hydraulic Spreader, Serrated Shoes	Hydraulic Spreader, Stepped Shoes	Aluminum Holding Block	Lightweight Hand Pump	Manifold Assembly	Hoses	Handle for Spreader	Standard Case
FLS15-FBK	CE	2	-	2	1	1	3	2	1
FLS15-MBK	CE	1	-	3	1	-	1	1	1
FLS15-FBK-ST	CE	-	2	2	1	1	3	2	1
FLS15-MBK-ST	CE	-	1	3	1	-	1	1	1
FLS15-FBP		2	-	2	1	1	3	2	1
FLS15-MBP		1	-	3	1	-	1	1	1
FLS15-FBP-ST		-	2	2	1	1	3	2	1
FLS15-MBP-ST		-	1	3	1	-	1	1	1

▶ **Offshore Flange Spreader Kit**



**Features & Benefits**

- Heavy duty case is more rugged and compact, ideal for offshore applications
- Weather proof gasket seal and pressure equalization valve on the case
- Tighter product spacing for easier helicopter transport
- Gauges on manifold assembly display “bar” as primary units and “psi” as secondary

Order No.		Kit Contents							
		FLS15	FLS15-ST	SB15	P19L			2008577	3000832
		Hydraulic Spreader, Serrated Shoes	Hydraulic Spreader, Stepped Shoes	Aluminum Holding Block	Lightweight Hand Pump	Manifold Assembly	Hoses	Heavy Duty Case, Large	Heavy Duty Case, Small
FLS15-FSK	CE	2	-	2	1	2	3	1	-
FLS15-FSK-ST	CE	-	2	2	1	2	3	1	-
FLS15-MSK	CE	1	-	1	-	-	-	-	1
FLS15-MSK-ST	CE	-	1	1	-	-	-	-	1

## HYDRAULIC SPREADERS/LIFTERS

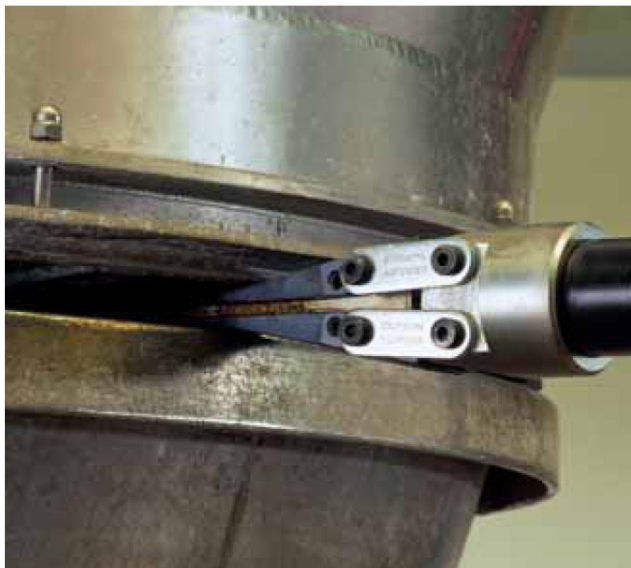

15 TLS



25 TLS

### Loads are lifted perpendicularly!

- Ideal for numerous industrial maintenance repair jobs.
- Accurate height adjustments (for instance shaft alignment) can easily be executed by one person.
- Easy, light and very practical to use. Particularly suitable when available space is very limited.
- Suitable for spaces of 5 to 43 mm.
- Due to the reduced thickness of the jaws, made of high quality hardened steel, these multi-functional wedges can be used for jobs where working space is extremely limited.

### Various combination sets\* available in carrying case, including:

- hydraulic spreader/lifter
- 2-stage handpump
- hose, 1.8 mtr
- pressure gauge
- T-adapter
- male (hose) half coupler
- complete quick coupler

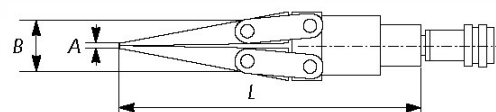

Type	Art. no.	Capacity ton	Max. spread mm	Max. pressure bar	Combined pump	A mm	B mm	L mm	Weight Kg
15TL	78170	15	10	700	single-acting	5	40	235	4
15 TLS	789150	15	10	700	single-acting	5	40	235	4
25 TLS	789250	25	16	700	single-acting	8	43	342	8

\* see price list